



700 SERIES

7" Colour Video Intercom System



User Guide and Installation Manual

SPECIFICATIONS

WIRING

Distance:
TOTAL Cable Length 70m Maximum

Recommended Cable Type:
Signal Wires: 4 Core 14/020
Power: 14/020 Figure 8

Note:
Cable diameter required is 0.5mm² per signal conductor
When using Cat 5 Join 2 conductors per signal wire

Configuration:
Door Station – Monitor 1 – Monitor 2 – Monitor 3 – Monitor 4
Each Monitor is individually powered

7" TFT MONITORS

Max Per System 4
Power Voltage 12VDC
Current Draw 700mA
Dimensions mm (W,H,D) 212 x 144 x 20

DOOR STATIONS

Max Per System 2
Current Draw 300mA
Dimensions mm (W,H,D)
Surface 124 x 90 x 30
Flush (finished on wall) 165 x 110 x 2
Slimline exc. Angle 95 x 150 x 38

IP Rating IP55

GATE RELEASE

Relay Contact Only
Rated Voltage 12/24VDC
MAX Current 1 Amp
Release Time 5 Seconds (variable)

PICTURE MEMORY

Storage Location/Viewing On Board
Memory Capacity Approx 50

GENERAL LAYOUT

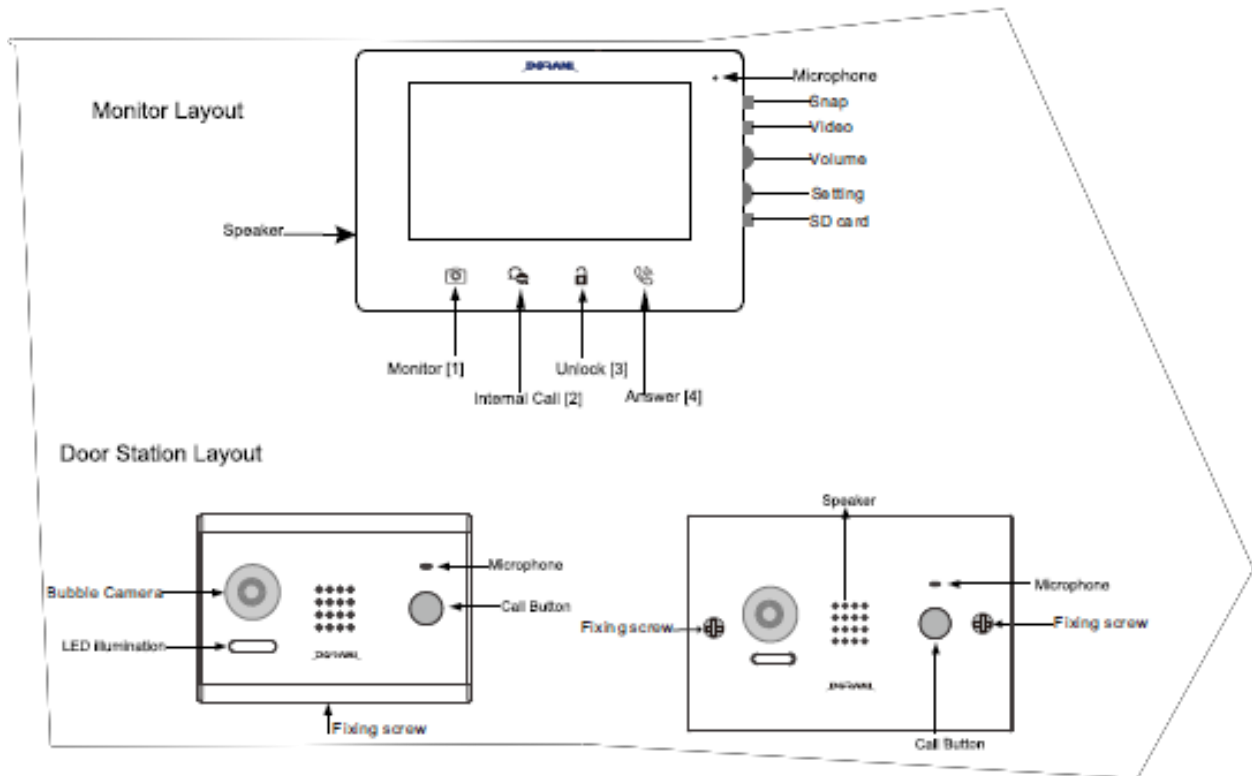

GENERAL OPERATION

Placing and Answering a Call

- To instigate call Press Intercom Call Button on Door Station
- The Intercom Monitor will Ring and the Video Image appears
- Press the Answer button to initiate communication
- Press the Unlock button to unlock if a locking device is connected
- Press the Answer button to hang up the call

Viewing the Outdoor Station

- Press Monitor Button on the Indoor Monitor

Calling Internal Room Monitors

- Press the Internal Call button and ALL monitors in the system will ring
- At the monitor being called press the Answer button and communication will start
- Press the Answer button on either monitor to finish the call

MENU OPERATIONS

Note: If a User does not operate any of the functions on the indoor device for 1 minute, the system will enter standby mode automatically

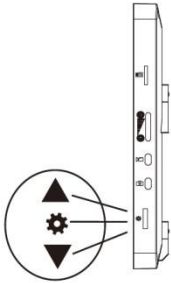

This “ ⚙ ” button is a 3 way button:
Press IN for Enter
Scroll UP and DOWN to move cursor to desired location

In standby mode, press the button “ ⚙ ” to access the main menu interface as shown below.

Main Menu Interface



System Menu



This Menu enables the user to change the General system settings

Language Time and Date Information

Ring Menu

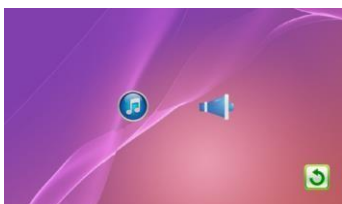

This Menu enables the user to change the Ring Tone and Volume

Mode Menu



This Menu is an Installer level Menu

Master/Slave Setting

Unlock Time Setting

Alarm Menu



Please Note:

This Menu is NOT functioning in the Australian Dorani product range

Color Menu

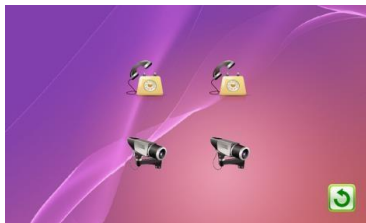

This Menu Allows the Brightness, Contrast and Colour Adjustments for Door Stations

Please Note: The Camera function is not functioning in the Australian Dorani product range

Folder Menu



This Menu Allows for the viewing and deleting of Picture memory files

INSTALLATION

CABLING

Cable diameter of 0.5mm² Stranded (twisted) **MUST** be used to achieve maximum distances specified.

Recommended: 4 Core Security - 14/020 - 1 Conductors per Bus Line Wire
Cat 5 – 1 Pair (2 conductors) per Bus Line Wire

Lock release will require an additional 2 cores for 12V Power feed to door station

Alternative Cables may be used –Cable distances and picture quality may be compromised.

INSTALLATION

LOCK RELEASE

Note: The Lock release on the door station is a RELAY only NO/C – Power is Required if an electric Strike is to be used.

Electric Strike Connection

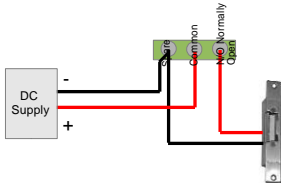

Momentary Trigger (Door Control)

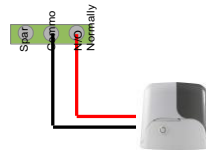

Request to Exit (Momentary ONLY)

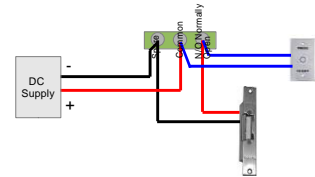

Single Door Station Cabling

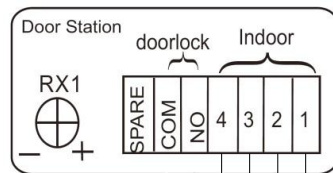

IMPORTANT SETTING:

Coax Switch - J1
ON - Monitor 1
OFF – Monitor 2,3,4

Coax Switch - J2
ON - Last Monitor
OFF – All Others

Monitors 2,3,4
SLAVE monitor must be selected in MODE Menu

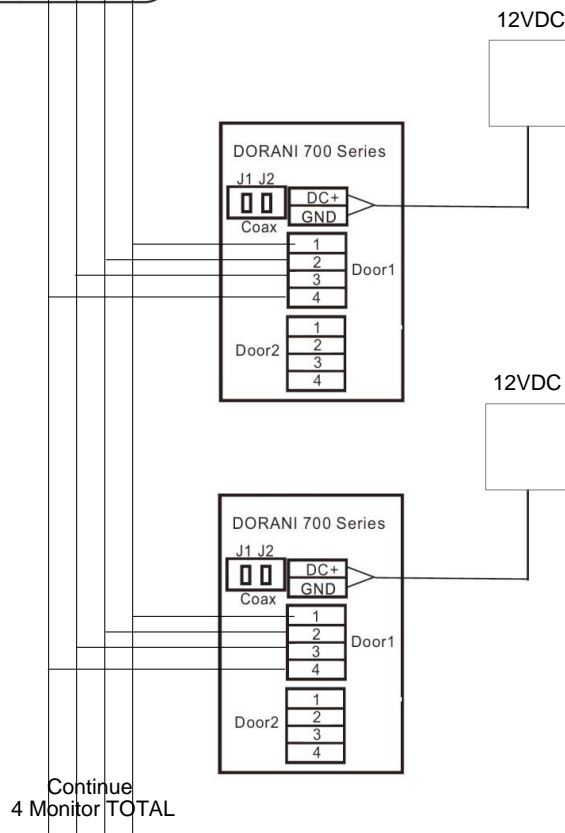

2 x Door Station Cabling

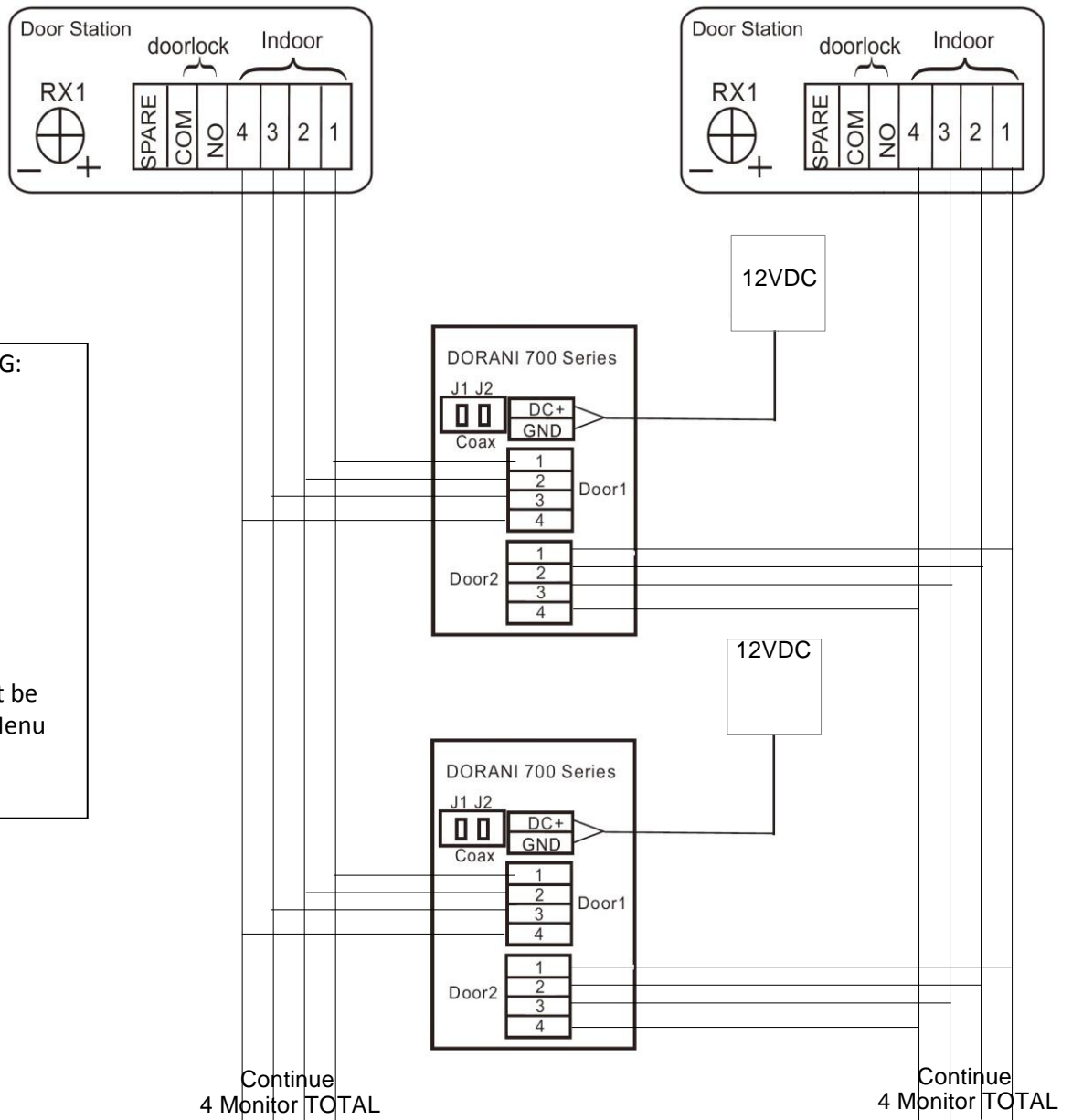

IMPORTANT SETTING:

- Coax Switch - J1
- ON - Monitor 1
- OFF – Monitor 2,3,4
- Coax Switch - J2
- ON - Last Monitor
- OFF – All Others

Monitors 2,3,4
SLAVE monitor must be selected in MODE Menu

CONGRATULATIONS, on your new Dorani Video Intercom Product

Dorani Video Intercoms pride themselves on providing innovative solutions in domestic, commercial and apartment video intercom systems.

We endeavour to provide all of our clients with the highest level of customer service, and ongoing product support.

We value your feedback, and provide you with our warranty details below.

Warranty

All Dorani Video Intercom products come with a limited 24 month warranty from time of initial purchase.

Damage caused by incorrect installation, negligence, abuse or malicious damage is not covered.

Damage from power strikes, surges, insect or vermin damage is not covered.

Warranty is as per Dorani Pty Ltd standard terms and conditions.

If you have any queries on the warranty of your product, please do not hesitate in calling your installer or local distributor found on our website dorani.com.au.



140 Cheltenham Road Dandenong VIC 3175
(03) 9701 3177
sales@fmhometech.com.au

9.00 - 5.30pm Monday to Friday
9.30am - 1pm Saturday



390 Middleborough Road Blackburn VIC 3130
(03) 9877 3799
sales@ausnetdigital.com.au

9.00am - 5.00pm Monday to Friday
9.00am - 12 noon Saturday



21 Yuilles Road Mornington VIC 3931
(03) 9783 9488
sales@ductedvacuum.com.au

9.00 - 5.00pm Monday to Friday

 fmhometech.com.au/intercom-systems